

THE NATURE AND COMPUTATIONAL USE OF A MEANING REPRESENTATION  
FOR WORD CONCEPTS

NICK CERCONE

*Department of Mathematical and Computing Sciences  
Old Dominion University, Norfolk, Virginia 23508*

## ABSTRACT

Various representations have been used to portray the meanings of word (notably action) concepts. The most prominent of these include decomposition trees, linear representations such as the Predicate Calculus, and semantic networks. The proposition-based semantic network notation developed by Schubert (1974) is especially well suited for including pragmatic and semantic information as part of the meaning representation of individual word concepts. The attempt is made in this paper to explore the nature of word concepts whose meanings are represented as semantic networks and to investigate their computational use within the framework of a natural language processing system.

## I. INTRODUCTION

The meaning of a concept is explained in terms of other concepts and through its relationship to other concepts. Various representations have been used to portray the meanings of concepts. The most prominent of these include decomposition trees (Lakoff, 1972; Wilks, 1973), linear representations such as the Predicate Calculus (Sandewall, 1971), and semantic networks.

Natural language processing systems can conveniently utilize factual knowledge represented in the form of semantic networks. The visual suggestiveness of semantic networks aids both in the formulation and exposition of the computer data structures they resemble. The use of semantic networks can be found in the works of many authors writing on natural language processing (including Schank 1972, 1973; Quillian 1968, 1969; Simmons and Bruce 1971; Rumelhart et al. 1973; Anderson and Bower 1973; and Palme 1971) as well as other forms of understanding (including Winston 1970; and Guzman 1971).

In utilizing semantic network representations, these authors have made use of the following characteristics of semantic nets. First (and most important), nodes that denote the same concept are not duplicated (in most cases). It is

then possible that distinct propositions may impinge on a node via arcs. Second, propositions are formed by linking predicate names to their argument nodes using arcs. Third, since concepts are not necessarily word concepts, particular and general concepts are represented as labeled or unlabeled nodes of a graph. Propositions may also have nodes associated with them. Finally, propositions in a semantic net are not assumed to be asserted (even though some researchers treat all nodes as implicitly asserted).

The proposition-based semantic network notation of Schubert (1974) is especially well suited for including pragmatic and semantic information as part of the meaning representation of individual word concepts. These meaning representations are networks based on propositions that consist of an n-ary predicate with a finite number of arguments. Terms used in the network to represent a given word concept can also be represented by semantic networks. Thus there is no insistence that a given set of "primitives" form the basis for the meaning of a word.<sup>1</sup>

The next section illustrates the use of semantic networks to represent the meanings of word concepts. Subsequent sections sketch methods that involve the computational use of these meaning representations in parsing and interpreting natural language text.

## II. MEANING REPRESENTATIONS FOR WORD CONCEPTS

Cercone (1975) divides his lexicon into open class items and closed class items. Typically, closed classes have a strictly limited membership which cannot be increased by adding new formations or loanwords (which are words that have been incorporated by one language from another language). The significance of closed class items is best expressed by their grammatical function. In contrast, open classes have a large, readily increasing membership. New formations and

loanwords are easily integrated.

Associated with open class category words are meaning representations: one for each sense of the word. The structure of a meaning representation is based on the semantic network notation developed by Schubert (1974). Pragmatic and semantic information are included in the meaning representation.

Figures 1 through 6 show networks that illustrate some of the main senses of the word drink, concentrating on action aspects. For illustrative purposes Figures 1, 3 and 6 are divided into a pragmatic section and a semantic section. The pragmatic section includes the template(s) that guides the parse of the utterance and two lists: the first list contains propositions that represent the implications that are likely to be needed for the comprehension of subsequent text; and the second list contains propositions representing critical implications that we expect to match in the surface structure. In Figure 1 this first list is (P3) and the second list is (P1,P2). The semantic section contains the network that represents the meaning of the word sense. Figures 2, 4, and 5 show various nominal senses of the word "drink".

Notice that Figures 1, 3, and 6 all have the notion of change in containment location in common. This corresponds to a general concept that subsumes not only differing senses of "drink" but also other more specific concepts as well, like "eating" or "receiving an enema". This observation has led to the following consideration.

When creating the meaning representations (networks) for concepts it is desirable to avoid the duplication of propositions in storage. If we extract more general concepts from the specific concepts that they subsume (totally or in part), we can avoid duplication by associating the common propositions with the more general concept.

In a sense the work of both Schank (1972) and Wilks (1973) supports the contention that the meaning of a concept is best represented by predications at the highest level of generality that adequately explain the term's meaning. Thus we extract from "drinking" (and eating, etc.) the structure shown in Figure 7.

We might reasonably label the concept expressed by this structure "ingest". It is important to note, however, that while Schank and Wilks might conclude that "ingesting" is a primitive action, that I consider it a general concept. This applies to all primitive actions put forward of Schank and Wilks. Examination of Figure 7 shows clearly that ingesting is not a primitive action but one whose meaning is expressed in terms of causes, motion, time, and other concepts.

At this point the original representations for the various action senses of "drink", i.e., Figures 1, 3, and 6, can be replaced with simplified diagrams based on the general concept "ingest". Figure 8 shows the representation of "drink" expressed in Figure 1 redrawn in terms of the general concept "ingest". In similar fashion Figure 9 diagrams one meaning of "eating", again based on the general concept "ingest".

The key to making effective use of the meaning representation for comprehension centers on the propositions that contain arguments that we expect to match in the surface utterance. The lexical item for "drink" would contain, among other things, pointers to a list of propositions; these propositions contain the arguments that we expect to match with words in the text and are most frequently needed for comprehension. At times, however, other propositions may be required for comprehension. For example, the word sense illustrated in Figure 1 shows that we expect to find, in an utterance about drinking, an anim(x) and a liquid(y) propositions P1 and P2. But the question can be posed, "What is the effect of John's drinking". To answer this question would entail a further investigation

of the other propositions in the network, especially the first list of implications. Although it is implicit in the semantic structure, we make explicit in the pragmatic structure the inference that "x - drink - y" necessarily implies that it causes y's location to be in x at some time after x initiates the drinking action. Of course, since this implication is common to all senses of "drink" (and eats, inhales, etc.) it is abstracted into the same general concept "ingest" as well, as shown in Figure 7.

The semantic structure for each word sense for "drinks" is represented as properties attached to the word sense. The main properties include ARGS, the argument list containing arguments used in the word sense; IMPLICS, a list of implications that accompany the word sense; the propositions P1, P2, etc. that relate the arguments and predicates that make up the network explicating the given word sense; and templates of the form

arg1 arg2 ... argi WORD argi+1 ... argn

The implications make the most commonly used inferences part of the meaning representation of word concept. The propositions, for example P1 and P4 are shown Figure 10. See Cercone (1975) for sample lexical entries, in particular the entry for "drink".

Many advantages accrue by representing meaning formulas in this way. First, unlike Wilks' (1973) meaning formulas, the representation is suggestive of the meaning of a word. I see no justification for (binary) lexical decomposition trees as meaning representations for words as such trees are neither suggestive of the type of processing required nor of the propositions they encode.

A second and major advantage is this. The meaning representation for a word is not required to be explicitly in terms of "primitives". Rather, each of the predicates in the propositions that form the network representing the meaning of

the word can, in turn, be represented in an analogous manner. In particular the notion of a "cause" seems to me to be no more "primitive" than "drink". This method of representing word meanings enhances the representational schema for the purpose of comprehension since any amount of detail can be included in the meaning representations by adding propositions to the networks.

Third, inference mechanisms, heuristic processing algorithms, and superimposed knowledge-organizing schemas can be incorporated using this representation for word meanings as easily as in any other representation. Incomplete information in surface text can be inferred, when necessary, directly from the meaning representation, in some cases as a missing argument.

The use of this type of meaning representation for lexical items is further explained in the next two sections.

### III. PARSING AND INTERPRETATION USING NETWORKS

Traditionally, the object of parsing sentences has been to output syntactic trees. These trees served as input to semantic routines charged with the generation of meaning structures. Winograd (1972) and Woods (1970) tried, with some degree of success, to integrate the two processes and use each process to guide the other process. Schank (1972) and Wilks (1973) have stressed that syntactic processing was secondary to meaning analysis and should be necessary only when the resolution of ambiguity by meaning analysis alone had failed. Utilizing network meaning representations the parsing phase is almost completely semantically oriented. One important by-product in the method to be described is the detection of the correct sense of nominals, modifiers and actions.

The parsing proceeds as follows. Words, in a clause that has been classified<sup>2</sup> are scanned from left to right in search of a suitable candidate for an action. Once found, the sentence is separated into ((FIRST PART) (ACTION CANDI-

DATE) (SECOND PART)). The action candidate contains, among other things, a list of possible action senses that this particular root form may have. These senses are ordered by a scheme, albeit a very superficial scheme, described in Cercone (1975). Associated with word senses are templates as described above. For example, the sense \*GIVE1 of the root form "give" has a template "X GIVE Y Z" and an alternative (ALTERN) template "X GIVE Z TO Y" associated with it.

The template, e.g. "X GIVE Y Z", is used to guide the parsing. In this example X, Y and Z are variables representing the arguments of the predicate "give" that we expect to find in the surface utterance in the given order. More detailed information concerning the arguments is obtained by examining the network propositions, for the sense of "give" in question, that involve the arguments. Thus X, in this case, would represent an ANIMATE nominal capable of "giving".

This is very similar to what Shcank does when parsing in conceptual dependency theory. If the words in the surface utterance do not satisfy the constraints for arguments of the predicate being examined, it is due to one of four reasons. First, alternate syntactic constructions could exist. Second, a different sense of the action is "correct". Third, the particular action candidate in question is not the action of the clause. Finally, some other reason, like slang expressions might be the cause.

Whenever arguments fail to satisfy predicates, a search for alternative implication templates begins. The result of this search is shown quite clearly, in Figure 11 of Section IV for the ternary predicate "give". In that example "give" is used syntactically in two different forms to distinguish the indirect object, one with the preposition TO and one without. If this approach fails then the list of senses for the root form is further examined. If other senses of the action candidate exist, they are examined further to see if arguments of

the action candidate in the surface utterance match' variables in the template. This procedure is repeated until the correct sense of the action candidate is found or the list of senses is exhausted. If the sense list is exhausted, scanning continues in the surface clause for another suitable action candidate and the process is repeated.

Part of the process of matching arguments of predicates in surface text to variables in implication templates involves finding the correct sense of nominals and modifiers as well. The sentence "A drinker drinks many drinks" has as the second argument of the predicate "drinks" the word "drinks". Possible nominal senses for that "drinks" include an alcoholic beverage, a body of water (throw John into the drink), or a thirst quencher. Thus, if the first sense of a nominal fails as argument, all other senses must be examined before deciding not to accept it as argument. This reasoning applies with respect to modifiers in a similar but not identical fashion. For instance, a "yellow cake" is a type of cake much like a chocolate cake whereas a "yellow car" is something that is yellow and something that is a car. Using these methods, sentences such as "A drinker drinks many drinks" and "The pilot banked his plane near the river bank over the bank that he banks on for good banking service" present little difficulty.

Morphological analysis is important since only those forms that can authentically be considered as actions need be examined. In the example, "A drinker drinks many drinks" the word "drinker" is eliminated immediately as an action candidate due to morphological analysis. Thus, we are very quickly able to get a right choice for an action candidate.

The next section shows an example of parsing and the resulting semantic network constructed using meaning representations of the type described.



IV. SOME EXAMPLES

72

The following example is taken from Cercone (1975). Many other examples can be found there. The sample listing preceding Figure 11 gives the results of the parsing phase, clause by clause, under the heading +++ ASSOCIATED ACTION-ARGUMENT-VARIABLE TRIPLES +++.

```
# R NEW:MACLISP
# 12:23.49
= (RESTORE 'CHKPT)
=   NIL
= (UNDERSTAND)
=   READY
=
= JOHN GAVE JUDY THE
= RED BOOK. THEN, JUDY GAVE
= THE BROWN BOOK TO MARY.
=
=   +++ ASSOCIATED 'ACTION-ARGUMENT-VARIABLE TRIPLES +++
=   ((*GIVE1 *BOOK1 Z) (*GIVE1 *JUDY1 Y) (*GIVE1 *JOHN1 X))
=
=   +++MODIFIERS+++
=   ((NM (ADJ CLASF ((0 0) (*RED1)))) Z)
=
=   . +++ THE SEMANTIC NET +++
=   *ATOM*   *VALUE*   *PROPERTY*
=   PROP0001 *JOHN1    X
=   PROP0001 *JUDY1    Y
=   PROP0002 *BOOK1    PRED
=   PROP0002 INST0003  ARG
=   PROP0004 INST0003  ARG
=   PROP0004 *UNS0005  PRED
=   PROP0001 INST0003  Z
=   PROP0006 *RED1     PRED
=   PROP0006 INST0003  ARG
=   PROP0001 *GIVE1    PRED
=
=   +++ ASSOCIATED ACTION-ARGUMENT-VARIABLE TRIPLES +++
=   ((*GIVE1 *MARY1 Y) (*GIVE1 *BOOK1 Z) (*GIVE1 *JUDY1 X))
=
=   +++MODIFIERS+++
=   ((NM (ADJ CLASF ((0 0) (*BROWN1)))) Z)
=
=   +++ THE SEMANTIC NET +++
=   *ATOM*   *VALUE*   *PROPERTY*
=   PROP0007 *JUDY1    X
=   PROP0008 *BOOK1    PRED
=   PROP0008 INST0009  ARG
=   PROP0010 INST0009  ARG
=   PROP0010 *UNS0011  PRED
=   PROP0007 INST0009  Z
=   PROP0007 *MARY1    Y
=   PROP0012 *BROWN1   PRED
=   PROP0012 INST0009  ARG
=   PROP0007 *GIVE1    PRED
=   (MTS)
```

## V. CONCLUSIONS

The above sections outline what I believe to be the correct approach to representing the meaning content of word concepts. Hopefully the use of meaning representations such as these will simplify the problems inherent in representing the conceptual content of natural language utterances in terms of meaning structures. In particular, I see the following desirable features inherent in this approach.

### (i) Interpretive directness

The meaning structures corresponding to natural language utterances are formed according to simple structural rules. Powerful heuristic criteria, based on the central role of verbs and on preferred semantic categories for the subjects and objects of verbs, guide each choice in the creation of meaning structures. Interpretation of utterances then takes on a "slot and filler" character, rather than requiring extensive trial and error search.

### (ii) De-emphasis of syntax

In ordinary discourse it would be absurd not to accept "ungrammatical" constructions like dangling participles or fanciful locations such as metaphor. In the above approach a syntactic straightjacket is not imposed on admissible utterances. Therefore the abnormal is not excluded as it is in many linguistic systems.

### (iii) Emphasis on events

A major part of our interpretative effort in understanding natural language is focused on events, i.e., time-dependent relationships. By contrast, "static" relationships in the world are relatively easy to understand. Therefore the search for fundamental semantic structures should concentrate on the representation of events. The use of meaning representations as described above facilitates this emphasis on events.

The handling of vagueness, events, the lexical meanings of complex concepts, and the problem of overall knowledge organization may raise additional problems when processing natural language with meaning representations such as the ones I have used. However, the meaning representations used in this paper can be viewed as an extension of several successful but superficially disparate schemata, such

as Schank's (1972) conceptualizations or Winston's (1970) descriptions. This indicates that their use should prove of real value in the design of understanding systems.

#### Acknowledgements

Many thanks are due to Dr. Len Schubert; his ideas and comments are interwoven in this research. I am also indebted to Dr. J. R. Sampson and Dr. K. V. Wilson for their careful reading and suggestions.

#### REFERENCES

- Anderson, J. and Bower, G. (1973). Human Associative Memory, V. H. Winston and Sons, Washington, D.C.
- Cercone, N. (1975). PhD thesis. University of Alberta. Edmonton, Alberta, Canada.
- Cercone, N. and Schubert, I. K. (1974). "Toward a State-Based Conceptual Representation", Department of Computing Science, TR-74-19, University of Alberta, Edmonton, Alberta.
- Davidson, D. and Harman, G. (eds) (1972). Semantics of Natural Language, D. Reidel Publishing Company, Boston, Massachusetts.
- Fillmore, C. J. (1968). "The Case for Case", in Universals in Linguistic Theory, E. Bach and R. Harms (eds), Holt, Rinehart, and Winston, New York, New York, pp. 1-88.
- Guzman, A. (1971). "Analysis of Curved Line Drawings Using Context and Global Information", in Machine Intelligence, B. Meltzer and D. Michie (eds), American Elsevier Publishing Company, New York, v 6, pp. 325-375.
- Palme, J. (1971). "Making Computers Understand Natural Language", in Artificial Intelligence and Heuristic Programming, N. Findler and B. Meltzer (eds), American Elsevier Publishing Company, New York, New York, pp. 199-248.
- Quillian, M. (1968). "Semantic Memory", in Semantic Information Processing, M. Minsky (ed), MIT Press, Cambridge, Massachusetts, pp. 227-270.
- Quillian, M. (1969). "The Teachable Language Comprehender", CACM, v 12, n 8, pp. 459-475.
- Quine, W., (1970). Word and Object, MIT Press, Cambridge, Massachusetts.
- Rumelhart, D., Lindsay, P., and Norman, D. (1972). "A Process Model for Long Term Memory", in Organization of Memory, E. Tulving and W. Donaldson (eds), Academic Press, New York, New York, pp. 198-221.

- Schank, R. (1972). "Conceptual Dependency: A Theory of Natural Language Understanding", *Cognitive Psychology*, v 3, pp. 552-631.
- Schank, R. (1973). "Identification of Conceptualizations Underlying Natural Language", in Computer Models of Thought and Language, R. Schank and K. Colby (eds), W. H. Freeman and Company, San Francisco, California.
- Schank, R., (1975). "The Role of Memory in Language Processing", Yale University Technical Report, New Haven, Conn.
- Schank, R., Goldman, N., Rieger, C., and Riesbeck, C. (1973). "Margie: Memory, Analysis, Response Generation, and Inference on English", Third International Joint Conference on Artificial Intelligence, SRI, Menlo Park, California, pp. 255-261.
- Schubert, L. (1974). "On the Expressive Adequacy of Semantic Networks", TR74-18, Department of Computing Science, University of Alberta, Edmonton, Alberta. See also Proc. IJCAI-4.
- Simmons, R. F., and Bruce, B. C. (1971). "Some Relations Between Predicate Calculus and Semantic Net Representation of Discourse", *Advance Papers of Second International Joint Conference on Artificial Intelligence*, The British Computer Society, London, England, pp. 524-530.
- Wilks, Y. (1973). "Understanding Without Proofs", Third International Joint Conference on Artificial Intelligence, SRI, Menlo Park, California, pp. 270-277.
- Winograd, T. (1972). Understanding Natural Language, Academic Press, New York, New York.
- Winston, P. (1970). "Learning Structural Descriptions from Examples", PhD Thesis, MIT, MAC-TR-76, Cambridge, Massachusetts.
- Woods, W. (1970). "Transition Networks for Natural Language Analysis", *CACM*, v 13, n 10, pp. 591-606.

## FOOTNOTES

- <sup>1</sup> Notable systems currently in vogue that utilize "primitives" in this way include those of Wilks (1973) and Schank et al. (1973).
- <sup>2</sup> Words in clauses are morphologically analyzed and, based on that analysis, they are classified to determine all of their possible syntactic functions in an utterance.
- <sup>3</sup> In Winograd's (1972) work, "gives" is recognized as a transitive action that requires two objects: his classification is TRANS2.

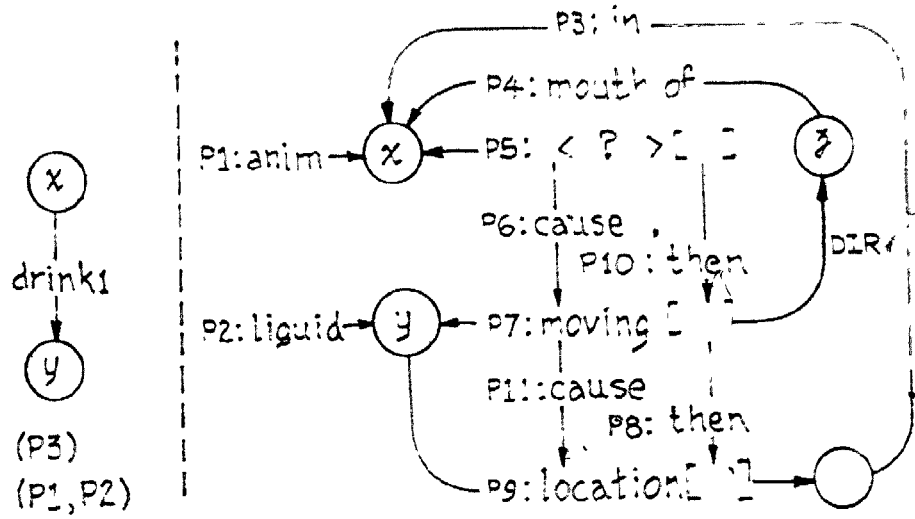

Pragmatics

Semantics

Fig. 1. "(John) drinks (water)"  
 "(Mary) drinks (prune juice)"

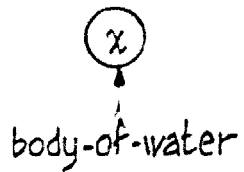

Fig. 4. "(Throw down in the) drink"

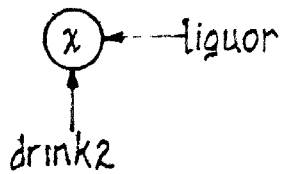
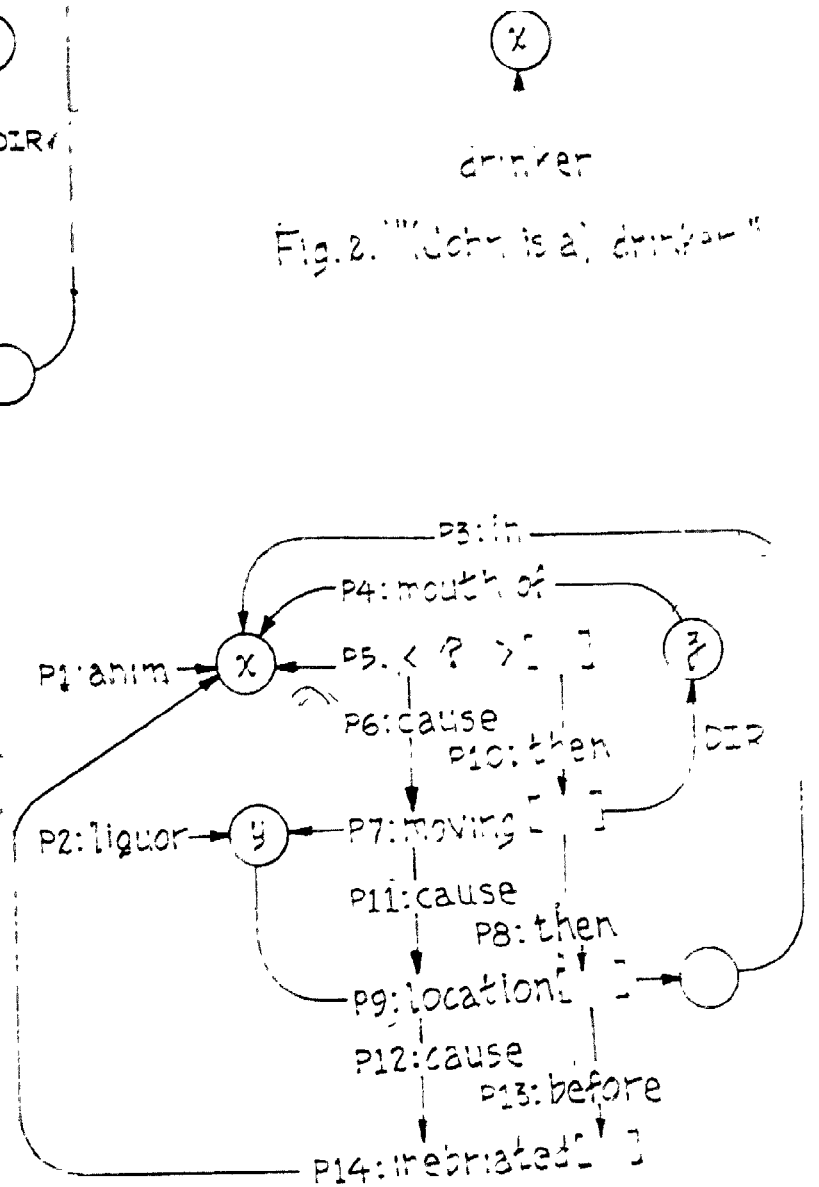

Fig. 5. "(John is drinking a) drink"



Pragmatics

Semantics

Fig. 3. "(John) drinks (whiskey)"  
 "(Maru has a) drinking (problem)"

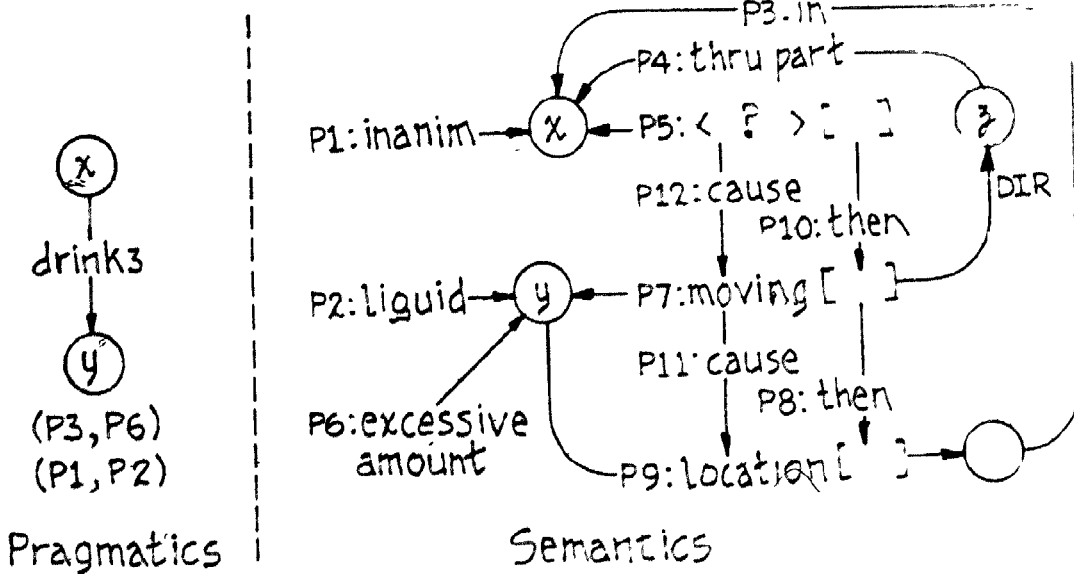

Pragmatics

Semantics

Fig. 6 "(My car) drinks (gasoline)"

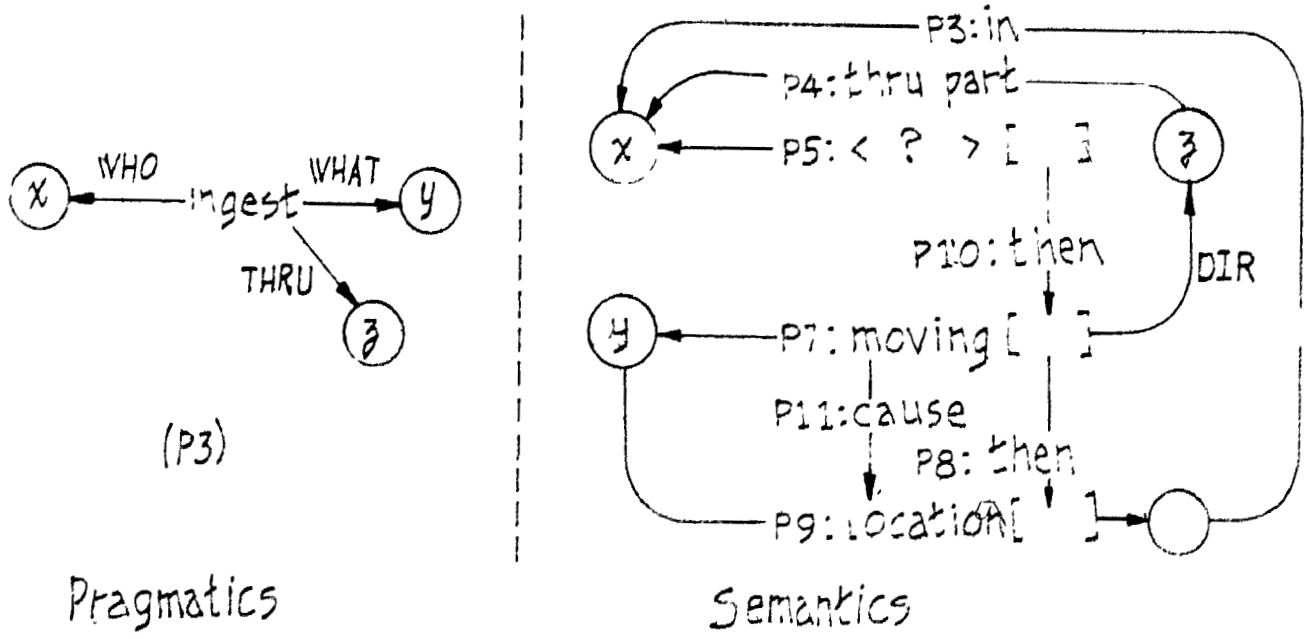

Fig. 7. "ingest"

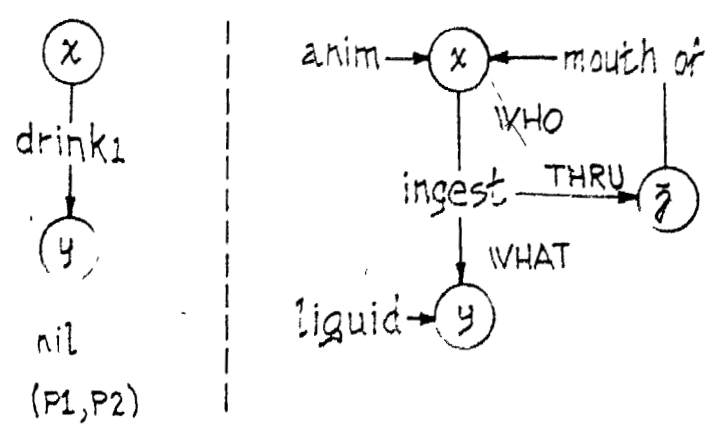

Fig. 8. "(John) drinks (water)"

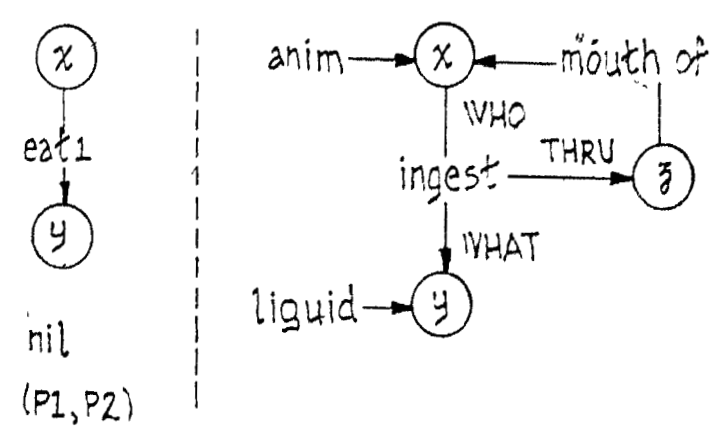

Fig. 9. "(John) eats (cake)"

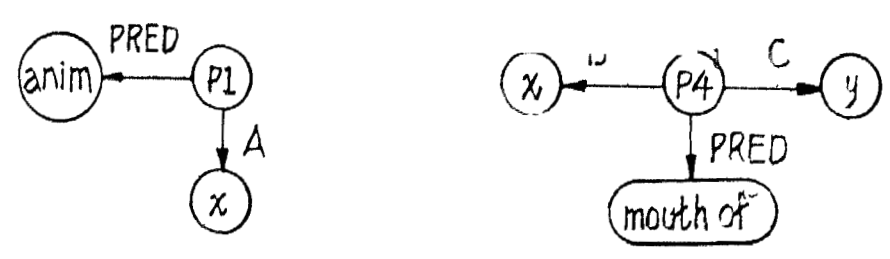
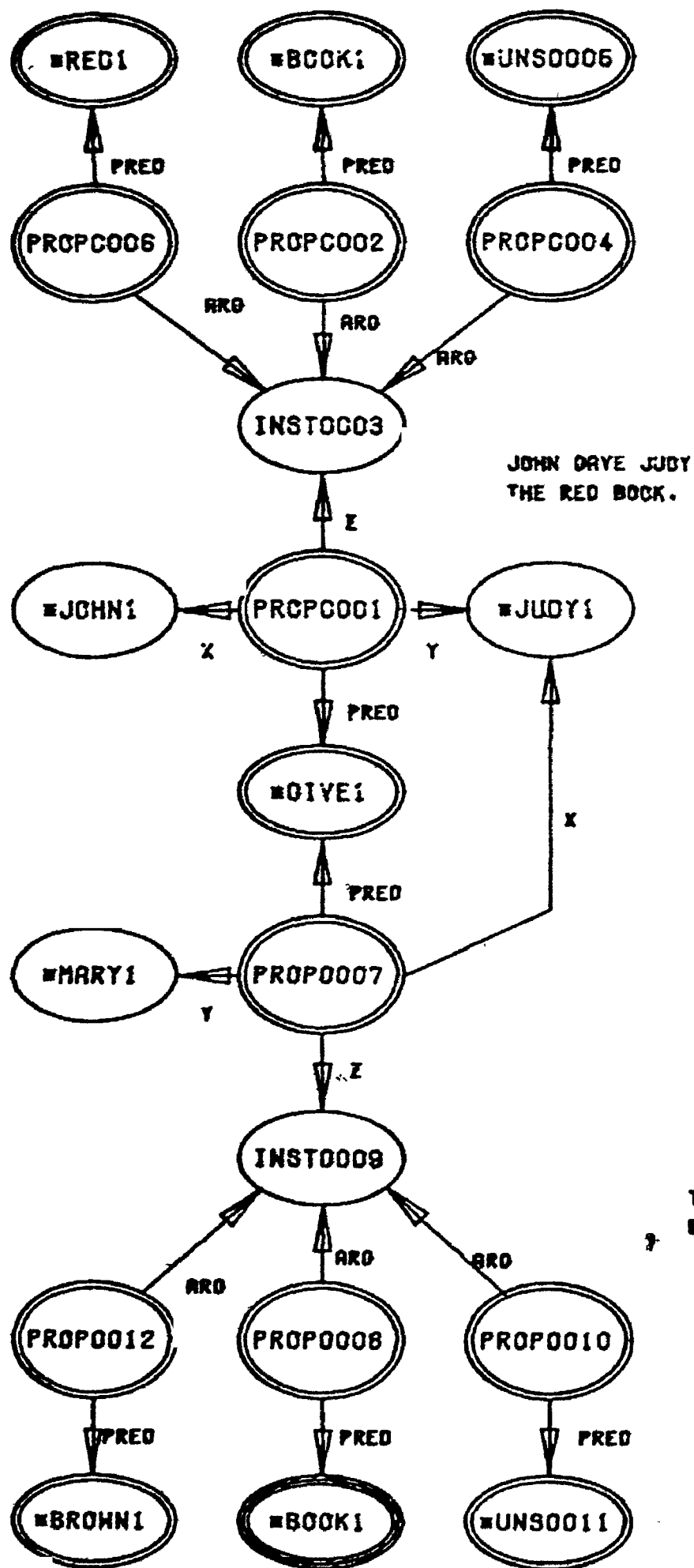

Fig. 10



JOHN GAVE JUDY  
THE RED BOOK.

THEN, JUDY GAVE THE  
BROWN BOOK TO MARY.

- NOTES:
1. PROP LINKS ARE NOT SHOWN.
  2. DOUBLY-CIRCLED NODES ARE PREDICATIVE CONCEPT NODES AND PROPOSITION NODES.
  3. TRIPLY-CIRCLED NODES SPECIFY ALREADY EXISTING NODES BUT AID PERSPICUITY.
  4. ARGUMENTS OF MONADIC PREDICATES ARE LABELLED ARG.
  5. ARGUMENTS OF NON-MONADIC PREDICATES ARE ORDERED AND LABELLED X, Y, ETC.

Figure 11. N-ary Predicate Network

Semantic networks present special problems with respect to the use of logical connectives, quantifiers, descriptions, modalities, and certain other constructions. Schubert (1974) has proposed systematic solutions to these problems by extending the expressive power of more or less conventional semantic network notation. In this appendix only the elementary part of the formalism, namely only as much as is necessary to clarify any misconceptions than may arise from the figures used in this paper, is explained.

In semantic network notation, the distinction between labels designating storage locations and labels designating pointers to storage locations requires clarification. This distinction is used by Quillian (1968) to designate "type nodes" (unique storage locations) versus "token nodes". The notation can be made uniformly explicit as in Figure A.1. Here "part-of", which in some notations corresponds to a token node, designates a type node (as suggested by Winston, 1970). All encircled nodes correspond to storage locations and all arrows to addresses of storage locations. What formerly were token nodes are now called proposition nodes; they serve as graphical nuclei for propositions as a whole.

At times the explicit notation of Figure A.1 will clutter the diagram leading to a loss in readability. Therefore, when the meaning is clear, binary predicates will be represented as in Figure A.2 for visual effect with the understanding that the use of explicit propositions underlie the structure.

In Figure A.1, A, B, and REL are mere distinguishing marks. They are analogous to parenthesis or commas in the Predicate Calculus in that they serve to relate denoting terms syntactically; they are non-denotative themselves. Whenever possible they will be chosen to be meaningful, i.e. to enhance readability and be suggestive, but they could be chosen as numeric labels as well.



One advantage of the explicit notation of Figure A.1 is that it works for n-ary ( $n > 2$ ) predicates. The sentence "John gives the book to Mary" involves "gives" as a three place predicate.<sup>4</sup> It is diagrammed as in Figure A.<sup>3</sup> Figure A.3 is appealing because of the significance we can attach to labels - agent, object, and recipient. By no means is Figure A.3 a graphical analogue of "case-structured" grammars. Cases are not viewed as conceptually primitive binary relations as Fillmore (1968) and researchers influenced by him, notably Schank (1972), view them. In a case structured system the central node would denote a specific action or process with the property that it is a "giving" and involves John, the book, and Mary as agent, object, and recipient respectively. Case relations can be understood as complex nonprimitive terms derived from such causally and teleologically related sequences of states. The whole notion of a case derives from the syntactic and semantic similarities between the role played by the arguments of many predicates. Nevertheless the notion of an "agent" seems to depend in part on causal priority of a state of the supposed agent in the sequence of states under consideration, and in part on the extent to which purposive behaviour can be ascribed to the supposed agent in general, and in part to the extent to which the particular sequence of states which he initiated can be assumed to be intentional on his part. See Cercone and Schubert (1974) for a further discussion of cases.

One final notational point by way of introduction needs to be made. The "case" labels in Figure A.3 are to be regarded as mere mnemonics, although indicative of more complex relations. To avoid confusion, predicate names will be designated in small letters and markers by capitals. Other conventions that are used include: solid loop for propositional nodes and existentially quantified concept nodes; broken loop for universally quantified concept nodes; solid lines to link the parts of a proposition to a proposition node; dotted lines for dependency links joining each existentially quantified node to all universally

quantified nodes on which it depends; and broken lines for logical links.

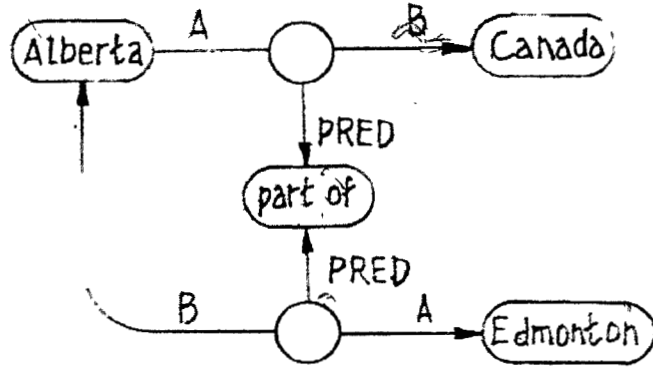

Fig. A.1 "Alberta is part of Canada.  
Edmonton is part of Alberta."

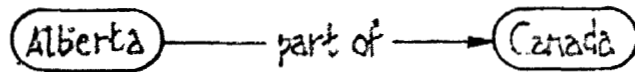

Fig. A.2 "Alberta is part of Canada"

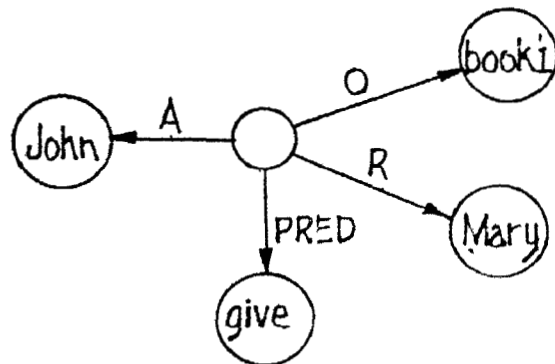

Fig. A.3. "John gives the book to Mary."

END

